

FIRE EXTINGUISHER CABINET

CLASSIC SERIES for 5 lb Dry Chemical Fire Extinguishers

MODEL: C - 100



SPECIFICATIONS:

- Door & Tub:** 18GA. Galvanized Steel Construction
- Size:** 20 1/2"h X 8 1/2"w X 6"d
- Finish:** Electrostatically applied baked white enamel paint
- Label:** UV Resistant Decal
- Includes:** Keyed Alike Cylinder Lock with Key
Scored Acrylic (17 7/8"h X 8"w)
Breaker Bar & Chain
- Packaging:** Individually boxed
- Option:** Recessing Frame Available
w/ 1/2" Turnback on trim
Adjustable depth

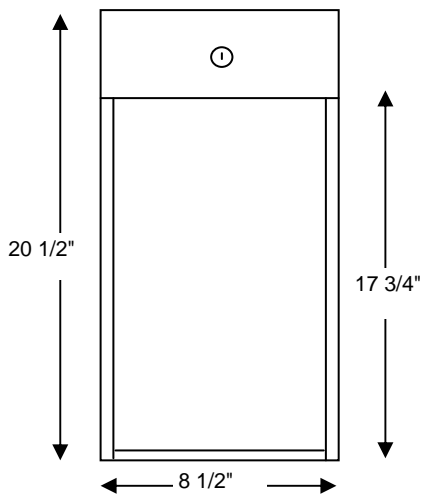

FRONT

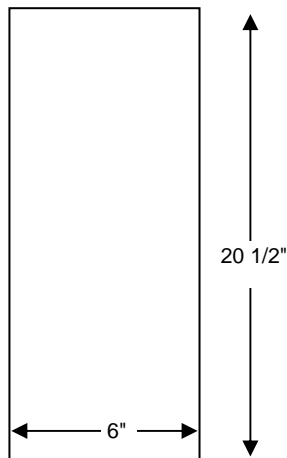

SIDE

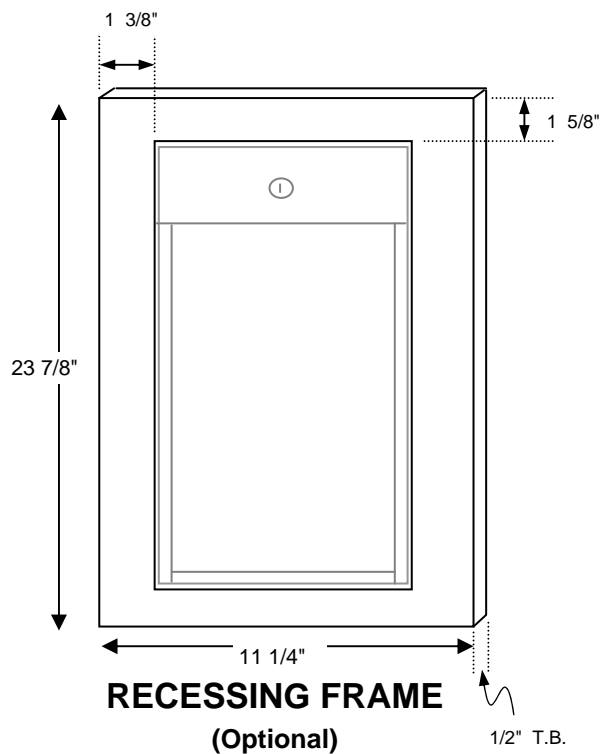

RECESSING FRAME
(Optional)