

9" x 24" x 6"

# FIRE EXTINGUISHER CABINET

## Semi-Recessed

### STANDARD CONSTRUCTION FEATURES

- 2" Rounded Turnback
- Full Glass Panel (4" x 19" Viewing Panel)
- 5" X 20" Glass Size (Standard)
- Grey or White Baked Enamel Finish
- Accomodates 10lb Dry Chemical Fire Extinguisher
- e.g. STRIKE FIRST model: WBDL-ABC10 (ULC Listed 6-A : 80-B : C)
- Stainless Steel Paddle Latch
- Full Legth Piano Hinge

### Options:

- 304 or 316 Stainless Steel (#4 Satin Finish)
- Stainless Steel cabinet equipped with invisable SOSS Hinges
- Full Metal Door
- Break Glass (6" Circle) w/ Lock Assembly & Decal
- Die cut vinyl decals/lettering

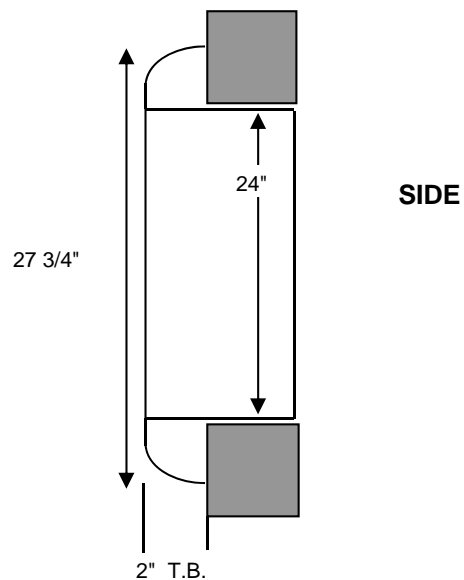
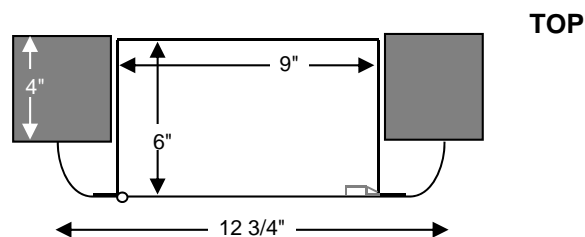
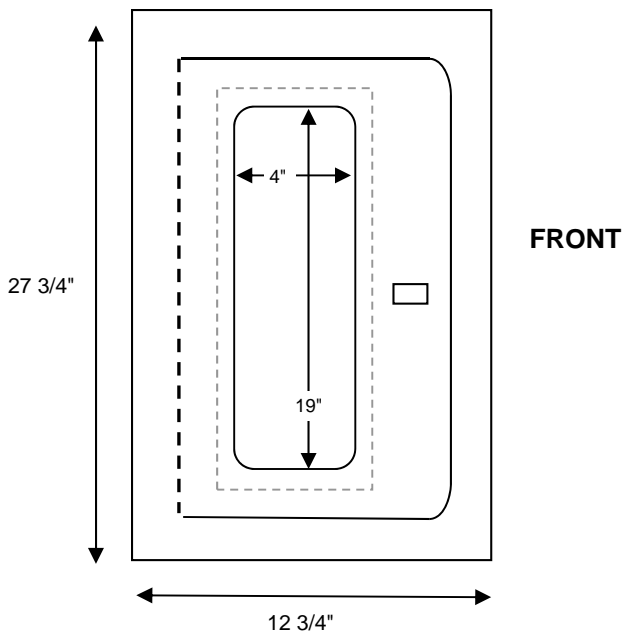

MADE IN CANADA

1455 Rue Pitfield, Saint-Laurent, QC, H4S 1G3  
TÉL : 514 333 3389 / FAX: 514 333 1887  
www.cfhsecurite.com

**CFH** Sécurité inc.  
Prévention Incendie