

FIRE EXTINGUISHER CABINET

CLASSIC SERIES for 20 lb Dry Chemical Fire Extinguishers*

MODEL: C - 104



SPECIFICATIONS:

- Door & Tub:** 18GA. Galvanized Steel Construction
Size: 30 1/8"h X 14 1/8"w X 9"d
Finish: Electrostatically applied baked white enamel paint
Label: UV Resistant Decal
Includes: Keyed Alike Cylinder Lock with Key
Scored Acrylic (27 1/2"h X 13 7/8"w)
Breaker Bar & Chain
Packaging: Individually boxed

* Can also accommodate a 10lb CO2

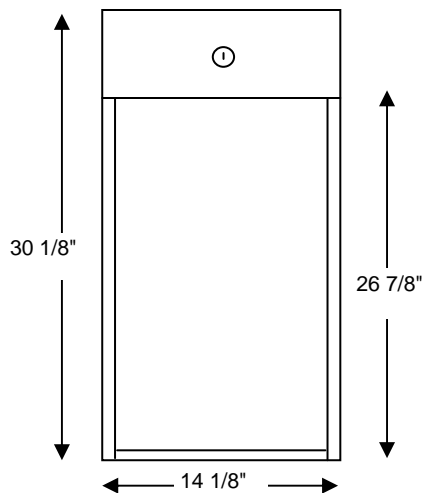

FRONT

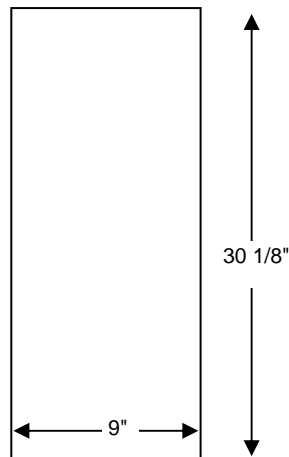

SIDE